

eLAN[®]

Energy Management and Control System with Web Interface facility built-in

How does eLAN[®] help you become more energy efficient?

eLAN[®], our online Energy Management System is designed to make companies more energy efficient. Today, over 231 of our customers, including manufacturing plants and organizations, just can't do without eLAN[®].

Here's why eLAN[®] should be a critical part of your energy management plan:

- eLAN[®] is an online system that works every second of the day, everyday.
- eLAN[®] tracks and helps control energy costs. Therefore, eLAN[®] is a powerful superset of mere Energy Recording systems and that difference is vital in bringing energy costs under control.
- eLAN[®] offers modules for Real-Time Energy Balancing and T&D loss tracking.
- The eLAN[®] Energy Billing module allows you to precisely allocate energy costs over tenants in a commercial complex or with equal ease, over a mix of products or work centers. You choose how and eLAN[®] does it.
- eLAN[®] Smart Power Planner helps you make smart power purchase or additional generation capacity decisions that are based on loads of actual consumption data, not estimates.

So, eLAN[®] does a lot more than just replicate energy readings. It ties in with key, specialized systems at your facility via Data Import/Export through periodic (Daily, Weekly, Monthly) Reports or online with the eLAN[®] ERP Link module straight to your Oracle or SQL database (ODBC database drivers also available).

What's more, eLAN[®] reports are accessible to authorized users even remotely over your LAN or through Web access.

Can my process control or building management also control energy?

- Effective energy management needs vast amounts of data, several times larger than that needed for effective Process Control or Building Management. Dedicated Energy Management therefore forms a superset. Complicating or overloading Building Management or Process Control systems to wedge in Energy Management as well, is usually either quite expensive or impacts response times of the primary control or security functions.

- Process Control or Building Management companies do not have in-house Energy Management expertise or Certified Energy Auditors. Energy Management and Energy Audits are vast specialized areas best tackled by the respective specialists.

Can eLAN[®] support process control or security?

- Several eLAN[®] Modules are available for control tasks in maintenance, energy control as well as interlocks and interfaces with Process Control/Automation or HVAC/Security/Building Management Systems.
- eLAN[®] is excellent for overall automation of production centers where line capacities have energy constraints. eLAN[®] can also integrate with most modern PLC automation systems, provided engineering documentation is available.
- eLAN[®] is not directly suitable for electronic gearbox, high speed feedback control or applications requiring sub-second response times. In such cases, we would engineer a suitable PLC subsystem.
- eLAN[®] can interface with low-level Sensor-Actuator interfaces for Building Management.

How can eLAN[®] help in meeting the provisions of the Energy Conservation Act, 2001 (India)?

- The Energy Conservation Act, 2001 (India), has designated 14 industrial sectors as energy intensive industries. These facilities must have a full time Energy Manager as well as a digital online Energy Management System. Through extensive study by experts, these have been found to be the most effective methods which yield attractive energy savings. One of the major provisions of the Act is timely reporting of energy consumption patterns and specific energy consumption to the designated authorities. eLAN[®] Energy Management System is the ideal solution as it can give all the required data online and the plant officials need not worry about generating separate data for this purpose.

So, what does eLAN[®] comprise?

Hardware

- ConzervTM Digital Multi-Function Meters*:
- These are specially designed for energy management.

- They offer direct-reading, scaled values, rapid communication response for real-time data as well as valid data even under unbalanced and distorted loading conditions. Revenue Meters are not good enough for Energy Management as they do not provide the sensitivity required for Energy Management. This is because billing standards call for accuracy only under sinusoidal waveforms. Since the billing is on a monthly basis, the energy counters may update only by one or two counts during the whole day. Hence, there is not enough sensitivity for online energy management and control.

*eLAN® can also integrate with third party meters at extra cost.

- Dedicated PC for the purpose of Energy Management
- Configuration : Pentium IV, 256 MB RAM, 80 GB Hard Disk Drive
- *Optional blocks such as PLCs and Sensors/Actuators for Process Automation or Building Management
- *Sensors/Analog Modules/Transducers for non-electrical parameters such as flow, pressure, temperature, etc.

Software

- eLAN® Software - choice of several Modules
- OS Windows 2000/2003 Server™/Professional, Windows® XP with Service Pack 1 and Microsoft® Office 2000/2003

- The price of the software depends on choice of modules and number of nodes

Network Components

- Data Communication cables
- Connector kits
- *Data Repeaters
- *Data Converters
 - RS 485 / 232
 - Ethernet to RS 485

Communication

- Supports multiple ports - 247 nodes max. per port
- 9600 bps
- Modbus RTU Protocol

Configuration and Support Services

- *Software customisation
- Installation and commissioning
- Remote support

*These depend on the choice of Core Modules selected in the eLAN® software. See page 5 for more information.

Energy Management System (EMS)

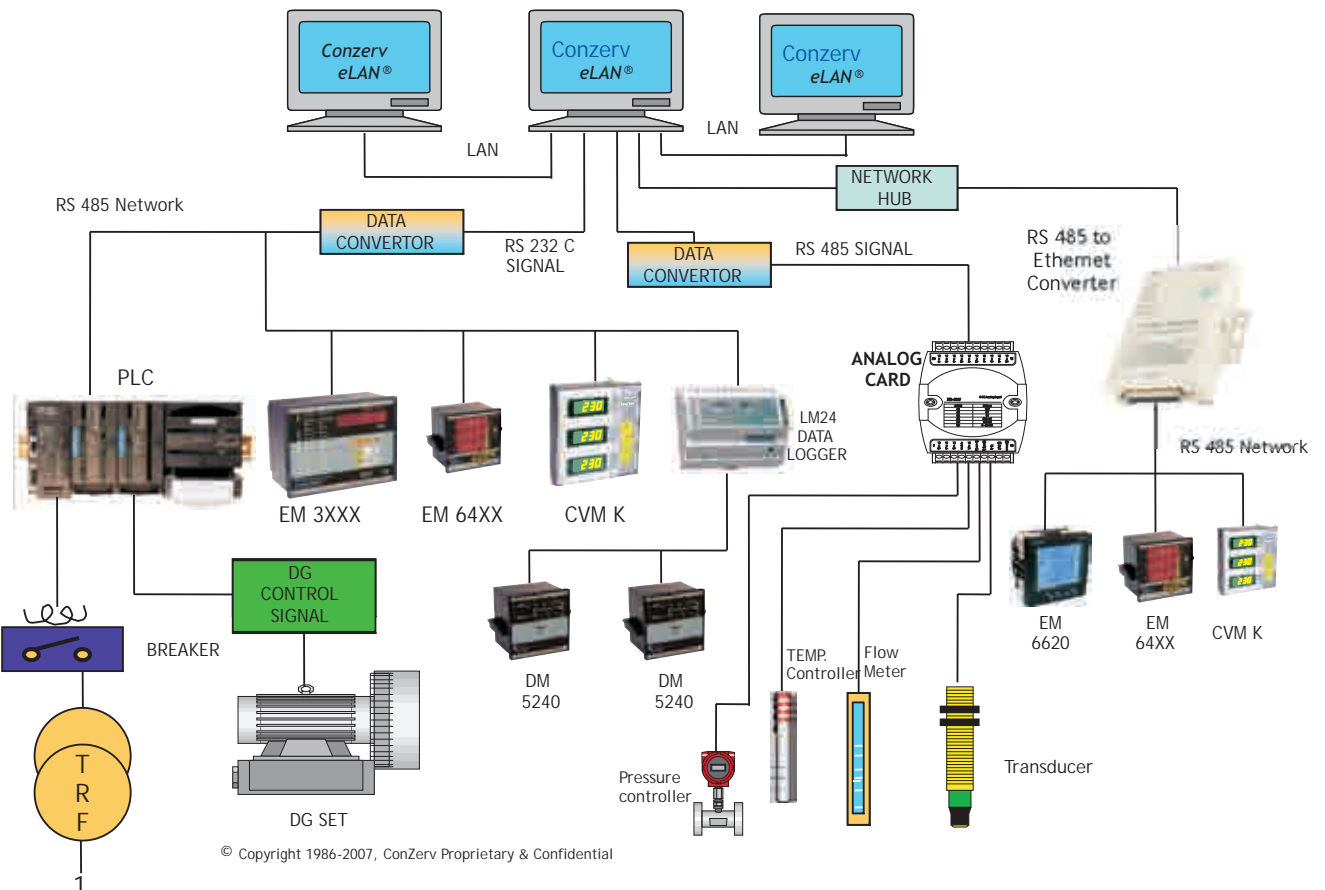

© Copyright 1986-2007, ConZerv Proprietary & Confidential

eLAN® Software Modules

- eLAN® Core Modules** : Provides an option to start with just one Core Module, eg.: the Electrical Energy Monitor. The Core Modules come with their own "Reports" which are largely readings tabulated shift wise, etc.
- eLAN® Linx Modules** : Helps you select the method of viewing of the Core Modules/linkage with other software such as ERP.
- eLAN® Boss Modules** : Comprises of powerful planning tools, each with its own specialized delivery. This is where eLAN® scores over any other package.

Select the eLAN® Modules YOUR business needs, in 3 easy steps:

- Step 1: Select one or more of the eLAN® Core Modules
- Step 2: Select one or none of the eLAN® Linx Modules
- Step 3: Select one or more or none of the eLAN® Boss Modules

eLAN® Core Modules

Sl.No	Name	What it does	Example
1	Electrical Energy Monitor	Measures energy consumption pattern at Mains, Feeders and Load Centres. Measures T&D losses and generates trends for both.	In a hotel, the T&D losses were 8% against the desired 3%. The cause was high neutral current, unbalance of loads among phases and presence of harmonics. The T&D losses were just one of the problems detected by eLAN®. The hotel got several other benefits such as detection of wastage of energy at restaurants after closing hours, excess power consumption in chilled water pumps as well as in the laundry during night shift. The payback period was less than 6 months.
2	Load Monitor	Electrical Energy Monitor Plus Maximum Demand Control at Mains and/or at Captive Set for Load/Source Management. Monitors and analyses load patterns. Monitors Demand and early warning through alarms if demand crosses limit. Monitors Apparent Power (kVA), Reactive Power (kVAR), Active Power (kW) and Power Factor (PF). Monitors voltage, current, RPM, etc.	In a large paper mill, eLAN® helped precise planning of loads through appropriate selection of chemi-mechanical or chemical pulp, without affecting the production rate. Maximum Demand came down by a whopping 4 MVA. The payback period - 2 months. Savings in Maximum Demand Charges.
3	Breaker Status Monitor	Monitors status of critical feeders with precise time stamp of trip. Gives status of feeders in changeovers, critical for load management. Tracks ON/OFF status of the bus couplers, import/export status with audio/visual indicators. Enables quick and easy fault analysis even if two or more breakers trip at once.	In a large petrochemical industry with several breakers spread over a huge area, a faulty breaker was identified in real time with precise time stamping. This would have taken 6-8 hours if there was no eLAN®. Prevented huge production loss. The cost of the system was recovered through preventing production loss from just two such trippings.

Sl.No	Name	What it does	Example
4	Load Control	Load Monitor Plus Breaker Status Monitor Plus Ideal for multiple electrical energy inputs from utilities, co-generation plant, Gensets, etc.	A plant running on Time-based Tariff needs to analyze the load profile and switch over to either the utility supply or captive generation. Helps optimize loading patterns.
5	Non-Electrical Monitor	Monitors non-electrical parameters like flow, pressure, temperature, etc. Generates Specific Energy Consumption data for non-electrical parameters.	In a co-generation plant, the flow rate, steam pressure and temperature of boiler feed water pumps was integrated with eLAN® to evaluate the steam generation and assess the boiler efficiency. The annual reduction in coal consumption by maintaining higher efficiency was equal to 15% of the cost of the system.
6	Generator Monitor	Load Monitor Plus Non-Electrical Monitor Plus enables online efficiency evaluation, load profile measurement of Genset. Generates Specific Energy Generation Ratio. Measures fuel consumption and calculates efficiency by comparing units generated to fuel consumed. Assesses Genset health. Obtains inputs from Coolant, Exhaust Temperatures (for efficiency & maintenance), Flow Meters for online fuel efficiency. Measures RPM, PF and kW (engine loading) as well as kVA (Alternator loading) to ensure generator is performing at rated levels. Generates alarms during Under loading (50%) and overloading (80%).	A Genset manufacturing company used this module for evaluation of Genset efficiency at customer sites. This helped to improve their competitive advantage over other manufacturers.
7	Power Quality Monitor	Load Monitor Plus THD, Harmonics, Neutral Current and waveforms at mains/different loads. Records Voltage and Frequency profile of Mains Power.	Power Consumption recorded at the mains in an Aluminum Company was higher than actual by 15%. eLAN® detected harmonics as the cause. Analysis showed THD and kWh pattern at feeders/main meter. Filters were installed resulting in savings. The payback period - 10 months.
8	Generator Control	Load Control Plus Non-Electrical Monitor Plus Controls Genset Breakers. Manages load sharing between Gensets. Controls ON/OFF based on actual operating load. Uses predictive demand function of the EM 3460 meters to switch Gensets ON/OFF. For Auto synchronization, use Conzerv's SynchroMax.	In a software company with frequent supply interruptions, all the gensets ran irrespective of load, leading to low fuel efficiency of the Gensets. Using this module, they were able to operate generators as per actual loads and improve the generator efficiency to about 3.3 units per litre from earlier 2.8 units per litre. The payback period was 18 months through improved Specific Energy Generation Ratio.

Sl.No	Name	What it does	Example
9	Process Monitor	Load Control Plus either Non-Electrical Monitor or 3rd party SCADA for measurement of Flow, Temperature, Pressure and Proximity. Helps calculate Specific Energy Consumption in real time. Links data from stand-alone control software like cooling tower control, HVAC, boilers etc.	In a cement company where idle operations of the crushers led to higher specific energy consumption, use of eLAN® interfaced with plant DCS indicated interruptions in material flow at the crusher. Improvements in raw material transport solved the problem and helped in reduction of Specific Energy Consumption. The incremental expense of extending eLAN® to the crusher was paid back in just 10 days.
10	Electronic Billing System (EBS)	Generates online billing solutions for commercial complexes, housing colonies etc. with single point billing by utilities. Generates bills automatically and emails to individual customers in the complex. Helps installations like IT parks which need additional data from Chillers, AHUs, Common Area power, etc., in addition to simple kWh billing. Measures T&D losses through measurement of consumption in common area separately from each floor or area.	Hitec City, an IT park with more than 80 offices, installed Energy Billing System to automatically generate bills for the offices and also to generate Energy Consumption profiles for all the common areas. Manpower cost was reduced by 30%. Total Cost was reduced by 20% through faster, more accurate billing. They were also able to initiate Energy Conservation measures to reduce energy consumption in common areas.

eLAN® Linx Modules

Sl.No	Name	What it does	Example
1	ERP Link Module	Generates online database Import/Export with other Automation Systems (Process Control/Building Management) through ODBC Drivers for Oracle 8 and SQL Server 2000, MS Access available as standard. Customizes other connectivity as per requirement.	Interlinking of DCS in industries and energy management system to transfer energy related data to DCS and transfer of production data to EMS for specific energy evaluation.
2	Local View	Views eLAN® data and reports on multiple PCs.	In a textile spinning mill the eLAN® server was located at the control room. PCs were connected as client at the Chief Engineer's office as well as at the Spinning Master's office to get energy and production data. Local View helped make decision making more effective.
3	Remote View	Suits companies with Multi-location Plants. Views energy data of all plants centrally. Allows access to authorized reports/central operation of software over your Office LAN/Web.	The Chief Manager of a Multi-unit petrochemical company views reports of all the plants centrally, in real time. Leads to inter-unit comparison of energy use, product mix, specific energy, etc.
4	Remote Support	Saves on-site costs for trouble shooting by using Conzerv Remote Diagnostics and Remote Expert services to keep your system running well. Ensures clear partitioning of data access through security settings.	A large poly-fiber company needed remote assistance and used this Module/Service for online trouble shooting to reduce downtime of the energy management system.

eLAN® Boss Modules

Sl.No	Name	What it does
1	T&D Loss Tracker	Gives network losses in absolute terms and percentage of total consumption by Energy Reconciliation and Balancing. Works with Load Monitor. Keeps I2R losses and unaccounted losses of the network under check.
2	Specific Energy Consumption (SEC) Tracker	Calculates SEC of kWh/kilocalories/total of all energy forms online and presents data on hourly/daily/weekly/monthly basis, for the whole plant/subgroups/process/load centers.
3	Generator Efficiency	Calculates efficiency of the Genset in percentage/units per litre of diesel and loading percentage for comparison.
4	Costing	Calculates Specific Energy Cost per cost center/Product/ Shift/Time band. Analyzes and cross-checks your Power Bill and Penalties. Tracks cost against norms and benchmark. Links to HR via Key Result Area achievement. Example: In a multi-product chemical company using different processes, this module helped to compute the actual cost of power process and product-wise. Helped allocate the precise cost of production to each product.
5	Smart Power Planner (SPP)	Generates Demand Curves. Combines with Costing Module for TOD (Time of Day) decisions and Generator Scheduling. Helps in determining the sources of energy to be used. Example: In a company making candy billed on time-based tariff, there were five time bands. With SPP, the company controlled Energy Consumption by scheduling operations, arranging batch processes, modifying utility equipments, etc., to reduce the billing.
6	Motor Load Analysis Report	Calculates Motor Loading (%), Losses (kW), Annual kWh consumption and operational cost.
7	Power Factor Improvement Report	Helps reduce the maximum demand and system losses. Reduces the maximum demand of the plant by Power Factor improvement. Minimises network heat losses. Helps get incentives/reduce penalties from supply utility (where applicable).
8	Equipment Efficiency Report	Calculates the performance of equipment like Pump, Fan, Cooling Tower, Refrigeration System, and Compressed Air System in percentage loading, output power, efficiency and losses, both Offline and Online : <ol style="list-style-type: none"> Plugs in your specific equipment characteristics. Arrives at actual characteristics by online measurement of load. Computes variance (a-b). Takes decisions for equipment life protection and energy savings.
9	Plant Analysis	Computes consumption and demand along with load factor for a load center or group of load centers for aggregation analysis. <ol style="list-style-type: none"> Average Daily Analysis - Displays a log for a 24-hour period for any day or combination of days. Enterprise Energy Efficiency Ranking - Ranks load centers in the enterprise to identify the most / least efficient with energy cost base. Equipment Operation - Displays run-time and run-time percentage for each equipment in plant. Exception Reports - Compares actual values versus baseline or against a defined range of values like Specific Energy versus Baseline. Relative Contribution - Energy Distribution within a plant.
10	Status reports as required by Energy Conservation Act, (ECA) 2001, (India)	Generates the various reports in the prescribed formats as given by Bureau of Energy Efficiency (BEE), for the designated industries under the ECA.

Industrial/commercial applications of eLAN®

1. Predictive Maintenance

eLAN® enables planned shutdown based on run hours and efficiency of equipment. Reduces downtime and helps plan predictive maintenance.

Example: In a Palm oil company, the screw press loses its efficiency because of timing, poor lubrication issues, etc., leading to breakdown and increased power consumption. The pattern of power consumption could be used as a diagnostic tool to assess the performance of the press and take decisions on the maintenance schedule.

2. Root Cause Analysis (RCA)

eLAN® analyses incidents like excess energy consumption, over-loading, excess T&D loss, machine breakdowns, breaker tripping, damages to capacitors, etc., for which RCA is necessary. Corrects problems in production rate and product quality by analysing the trends of energy consumption in relation to production.

Example: In case of a cement industry where the specific energy consumption of the crusher was abnormally high, the online energy consumption patterns in eLAN®, which was linked with the process control SCADA, revealed that the crusher was idle for a long period due to non availability of raw material. The huge power consumption of the idle crusher was the reason for the abnormal specific energy consumption of the crusher.

3. Measurement & Verification (M&V)

eLAN® covers the measurement and records energy consumption trends. Verifies results of energy saving measures taken. Enables achievement of both the objectives with precision, which assist in decision making.

Example: An automotive industry wanted to conduct M&V as their multiple products & processes meant verification was complex. eLAN® helped in assessing the actual benefits at different subsections in real time. This was a vital input to decision makers.

4. Energy Resource Planning

eLAN® monitors the grid supply billing, records and tracks the demand profile at the Mains supply and at the Genset. Helps control demand and avoid demand penalties. Helps optimise utilization of internal generation, automatic bill generation to verify the bill supplied by the utility company on unit consumption, costing, demand charges, power failures, etc. Helps planning of resource based on time-based tariff. Helps monitor the consumption pattern based on restrictions imposed by the grid, etc.

Example: A large chemical company had a Cogen plant with one condensing and six extraction turbines. Process fluctuations caused a mismatch of power and steam requirements resulting in venting/wastage of steam. eLAN® reduced wastage and thus cost by optimising the operation of the condensing turbine which was most affected by the venting and which also had the highest cost of generation. The payback period was less than 12 months.

5. Energy Balancing

eLAN® computes the energy balance at various nodes and the systems losses to formulate and implement Loss Elimination Schemes as any electrical distribution network has inherent system losses. Conducts overall energy accounting. Since energy use pattern of every feeder is monitored, any variation in power consumption pattern at any process or sub-section is exposed immediately for immediate control.

Example: In an engineering industry, with a large distribution network there was a mismatch in the overall energy consumption vis-à-vis the energy supplied to the industry. eLAN® found that some of the transformers were operating at low efficiency with extremely high losses. The loading on the transformers was optimized depending on actual loads at different sections like paint shop, electroplating, etc. This resulted in high energy efficiency.

eLAN® module selection guide for general application

Application	eLAN® Core Module	eLAN® Boss Module	eLAN® Linx Module
Predictive Maintenance	Generator Monitor Load Control	Equipment Efficiency T&D Loss Tracker Generator Efficiency Motor Load Analysis Plant Analysis	Local View
Root Cause Analysis (RCA)	Generator Monitor Power Quality Monitor Process Monitor	Motor Load Analysis Equipment Efficiency T&D Loss Tracker Specific Energy Generator Efficiency Costing Motor Load Analysis PF Improvement Plant Analysis	Local View Remote View
Measurement & Verification	Load Monitor Process Monitor	T&D Loss Tracker Specific Energy Generator Efficiency PF Improvement Equipment Efficiency Plant Analysis	Local View Remote View
Energy Resource Planning	Load Control Generator Monitor	Specific Energy Generator Efficiency Costing Smart Power Planner Plant Analysis	Local View Remote View
Energy Balancing	Load Monitor	T&D Loss Tracker Plant Analysis	Local View Remote View ERP Link
Energy Efficiency through Process Optimisation	Non-Electrical Monitor Load Control Process Monitor	Specific Energy Costing Equipment Efficiency Plant Analysis	Local View Remote View ERP Link
Genset Optimisation	Generator Control	Generator Efficiency Smart Power Planner	Local View ERP Link
Compliance with Energy Conservation Act, 2001 (India)	Generator Monitor Process Monitor	T&D Loss Tracker Specific Energy Generator Efficiency Costing Motor Load Analysis Equipment Efficiency Plant Analysis	Local View ERP Link
Online Electronic Billing	Electronic Billing System		

