

## 3Ø Electronic Energy Meters - DM 52 series

Enables direct energy usage reading, no external multiplication factor required. Can be hooked on to an Energy Management System, SCADA, PLC, DCS.



### Applications

- Electrical Panels
- Test Benches
- Wind Energy
- Co-Generation
- Genset Panels
- Lab Equipment
- Power Plants
- All types of Industries
- Load Centers

### Features

- True RMS
- Low PT, CT burden
- Accuracy class 1.0 IEC 61036 & Class 0.5
- Simultaneous sampling of Volts & Amps
- Accurate on distorted waveforms
- Sealed dust-proof construction
- Quick and easy installation
- Reverse LED for trouble shooting
- 3 phase 4 wire (& Single phase) - DM 5240
- 3 Phase 3 wire - DM 5230
- Industrial quality
- Field settable standard full scale
- Pulse output feature
- Tamper proof cover option

### Dimensions

Bezel : 96 x 96 mm  
 Depth : 80 mm behind Bezel  
 Panel cutout :  $92^{+0.5}_{-0} \times 92^{+0.5}_{-0}$  mm

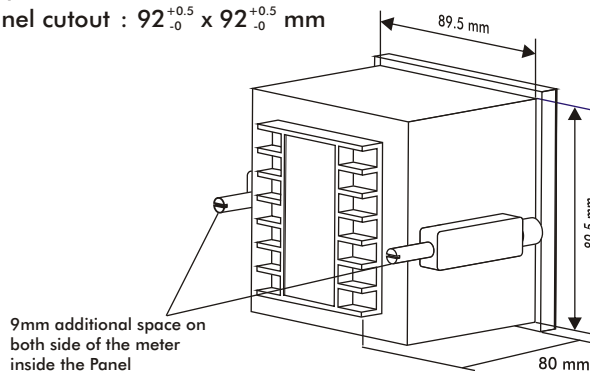

### Technical Specifications

#### Input (3 Phase 3 Wire / 4 Wire) :

##### V input overload withstanding

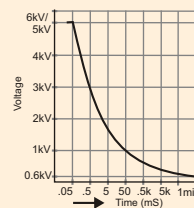

##### A input overload withstanding

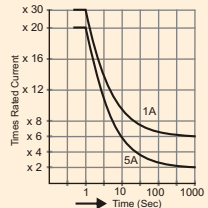

Nominal Voltage	Range	Nominal Current	Range
110 VLL	80 to 130 V	5 Amps	0.25 to 6.0 Amps
240 VLN	170 to 270 V	1 Amp	0.05 to 1.2 Amps
415 VLL	330 to 470 V		

##### Frequency

50 Hz / 60 Hz  $\pm$  5%

##### Power Factor

0.5 PF Lag-Unity-0.8 PF Lead

- Auxiliary Supply : Nominal 110 V Range 80-150 V (45 to 65 Hz)  
Nominal 240 V Range 170-300 V
- Burden : 0.2 VA max. per phase (Volts/Amps Input)  
3 VA max. on Auxiliary Supply
- Display : 6 Digit Impulse Counter.  
Max counts 999999.  
Tamper proof, Non-resettable.  
Retains the last recorded reading even under power failure conditions.
- Accuracy : Class 1.0 ; as per IEC 61036  
Class 0.5 ;  $\pm$  (0.25 % of reading + 0.25 % of Full Scale)

1 2 3 4 5 6 0 0 0

	0.4 to 4.0	4.1 to 40	41 to 400	401 to 4000	4,001 to 40,000	40,001 to 4,00,000
■ Full Scale kW $\sqrt{3}$ V Pri LL x A Pri						
■ Multiplying Factor: (Represented by decimal point)	0.01	0.1	1	10	100	1000
■ Resolution :						
- Counter : kWh/ Count	0.01	0.1	1	10	100	1000
- INTEG LED kWh/ Blink	0.01	0.1	1	10	100	1000
- Pulse Output kWh/ Pulse	10 or 8	10 or 8	10 or 8	10 or 8	10 or 8	10 or 8

- Overflow Hours : 2,500 - 25,000 (at Full Load)
- Pulse Width : 500 ms  $\pm$  50 ms
- Contact Rating : 24V DC, 100 mA Max
- Ambient : Temperature 0 - 50 C<sup>o</sup>  
Humidity < 95% Non-Condensing
- Weight : 450 gms approx.
- Dimension : Bezel: 96 x 96 mm
- Depth : 80 mm behind Bezel
- Panel Cut-out :  $(92^{+0.5}) \times (92^{+0.5})$  mm
- Mounting : Flush Mounting.
- Warranty : 1 Year from date of Invoice

## Know your DM 52

### Multiplying Factor (MF)

In the case of Direct Reading Meters, Multiplying Factor is the number by which Counter reading must be multiplied to get actual kWh consumed. The MF is indicated by decimal point of the Meter. In the case of 3 Phase 4 Wire Model DM 5240, calibrated for 415V/5A, the decimal point printed on the meter is 0.01. Each count on the Counter represents 1/100th of a kWh for direct input of 415V/5A. For the same meter when input is through a CT, depending on the CT Ratio an additional MF has to be applied by the user to get actual consumption. For example, for a CT Ratio of 100/5, the consumption is given by (Counter Reading) x 0.01 x 100/5 i.e., (Counter Reading) x 0.2. Thus, for a 500/5 CT, the Counter Reading directly gives the consumption.

### What do the POWER & INTEG LEDs on the front panel do ?

POWER LED indicates presence of Auxiliary Power which is essential for the meter operation.

INTEG LED indicates that integration of Energy is in progress. The LED Blink Rate is either 10 or 8 times that of the Counter update. Hence its resolution is 10 or 8 times that of the Counter and can be conveniently used for meter calibration.

### Overflow Hours?

As the Counter accumulates kWh, it will eventually reach 999999 and then overflow to 000000. The duration it takes to overflow is approximately equal to (999999) / average kW which the meter senses.

### TAMPER PROOF COVER OPTION

A Tamper Proof cover enables sealing of terminal block at the rear of the meter. This prevents tampering of connections.

## Pulse Output Feature

Optically Isolated, Solid-state NO Contact gives digital pulse output to drive Remote Counter, PLC, DCS Station etc. for off line monitoring of Energy Data, on line control for Energy/Power/Process optimisation, correlating Energy Input to product output etc. Applications of pulse output feature are as shown below.

**Process Integration**

Pulse output from DM 52 can be integrated into a process through a PLC/DCS for online control of Energy content in a process.

If the DCS/PLC has a self excited 12V or 24V Digital Input, external 24VDC Supply is not needed.

The kWh pulses may also be used to derive average kW information at the PLC

**Energy Totalizing**

Remote Totalizer can be configured to record Data shift-wise, day wise etc., while DM 52 records total consumption.

**Energy Management System**

Several DM 52s can be networked into a cost effective centralised system to centrally monitor energy data and generate a variety of reports covering load-wise, shift-wise, day-wise or batch-wise analysis of energy consumption.

**Energy Dispensing**

The Presettable Counter is programmed with the amount of Energy to be dispensed. When it counts down to zero, it de-energises the load.

★ Contact Conzerv for Energy Management Systems.

## Ordering Option Table

Specify

Model	Accuracy	Wiring	Frequency (in Hz)	Input voltage (in volts)	Input current (in amps)	PT ratio Pri/Sec (kV/VLL)	CT ratio Pri/Sec (in amps)	Aux supply (in volts)	Tamper cover
<input type="checkbox"/> EM 5230	<input type="checkbox"/> CL 1.0	3 phase	<input type="checkbox"/> 50	<input type="checkbox"/> 110	<input type="checkbox"/> 1	<input type="checkbox"/> 11/110	<input type="checkbox"/> 100/1	<input type="checkbox"/> 110	<input type="checkbox"/>
	<input type="checkbox"/> CL 0.5	3 wire	<input type="checkbox"/> 60	<input type="checkbox"/> 415	<input type="checkbox"/> 5	<input type="checkbox"/> 33/110	<input type="checkbox"/> 1200/5	<input type="checkbox"/> 240	
<input type="checkbox"/> DM 5240	<input type="checkbox"/> CL 1.0	3 phase	<input type="checkbox"/> 50	<input type="checkbox"/> 110	<input type="checkbox"/> 1	<input type="checkbox"/> 415/415	<input type="checkbox"/> 5/5	<input type="checkbox"/> 110	<input type="checkbox"/>
	<input type="checkbox"/> CL 0.5	4 wire	<input type="checkbox"/> 60	<input type="checkbox"/> 415	<input type="checkbox"/> 5	<input type="checkbox"/> 33k/110	<input type="checkbox"/> 200/5	<input type="checkbox"/> 240	

Note: One typical value for CT and PT ratio is shown above. Meters can be supplied with other ratios also.

### ACCESSORIES on order

Fused Voltage Probes & Clamp-on Current probes.

Conzerv strives for continuous product innovation. Product specifications are therefore subject to change without notice. **CONZERV**® is a Registered Trade Mark of Conzerv Systems Pvt Ltd

Energy Audits, Power Quality Audits, Tuned Harmonic Filters, Training on Energy Efficiency, Energy Management Systems, Reactive Power Compensation, Block Reactors, Power Factor Improvement, Multi-Function Meters, Intelligent Power Factor Controllers, Power Analysers, Portable Palm Top Analysers, Genset Synchronisation Meters, AMF Relays, Electronic Energy Meters, Digital Panel Meters, Static Watt Hour Meters, Power Capacitors HT & LT, Current Probes & Voltage Probes.

Conzerv Representative

Customer Help Desk 1800 425 0555 (Toll Free All India from BSNL / MTNL lines) Or Call 080 2852 0604 (Standard Charges Apply)

Email [contact@conzerv.com](mailto:contact@conzerv.com)

[www.conzerv.com](http://www.conzerv.com)